

10. Insert fingers on each lower corner and slowly lift it up and squashing the bubble created. Shape it for the mouth.

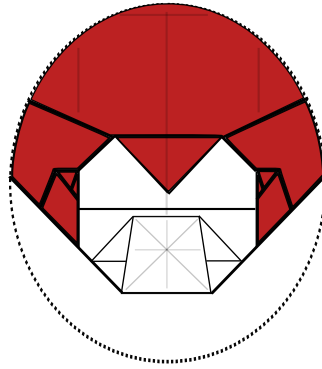

11. Step 10 completed. Zoom out.

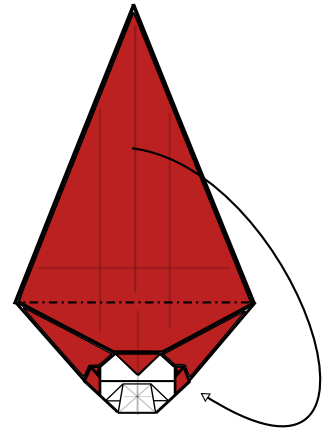

12. Fold the top back along existing crease.

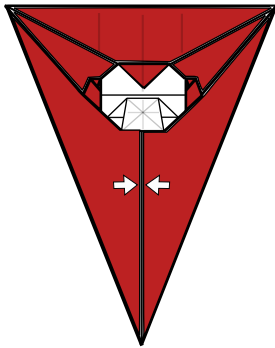

13. Open and release flaps outwards on both sides.

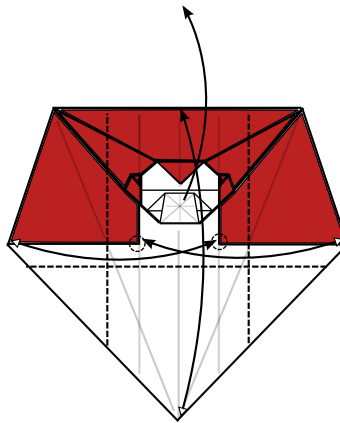

14. Fold/unfold: Bottom tip to top and both sides to existing creases made in Step 2. Make sure to crease firmly.

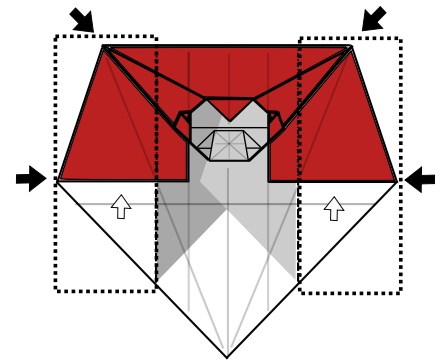

15. Sink fold the marked rectangle inwards on both sides by opening the flap and slowly pushing along the crease line made in Step 14. The grayed section is the final result.

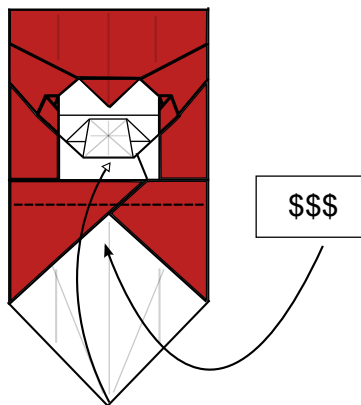

16. Insert the \$\$\$ here. Use existing crease, insert bottom section onto the pocket created.

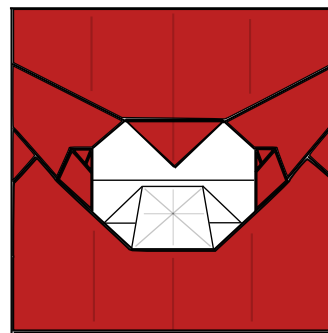

17. Completed. Kung Hei Fat Choy!
Gong Xi Fa Cai! 恭喜發財!